



GUIDELINES

COPINO Discharge Container Pre Announcement Order

(D95B version 1.3)

Department : PSA Antwerp EDI Support team

PSA Antwerp Guidelines COPINO

Introduction

This document is composed merely to facilitate the development of new EDI COPINO links with our customers and to guide and assist them through the programming and test phase. This should reduce the research and development on the customer side significantly.

As PSA Antwerp is an active participant of the world wide SMDG EDI discussion forum since its foundation, this document is partially based on the SMDG COPINO user manual (Version 1.3), enriched with some useful tips. It is not our intention to replace the official SMDG manual. These guidelines should be used in addition to the COPINO manual.

Suggestions and/or feedback are always welcome, as this document is also based on experiences, gained from past EDI projects. Each time some new features are added, we provide our customers with an update.

Best regards,

The PSA - Antwerp EDI Support team

COPINO discharge order for barges

The Container Pre Announcement Message for barges (COPINO)

The COPINO message is sent by the barge operator to the container terminal operator. It contains a list of all the full and empty containers to be discharged from a specific barge.

Containers discharged full from barge to be loaded on vessel at PSA Antwerp (for export purposes) or discharged empty destined to PSA Antwerp (import).

Containers discharged from vessel at a non PSA Antwerp terminal destined to PSA Antwerp (import).

The accuracy of the container information in this message is of innumerable importance. In order to send an up to date COPINO message, the discharge information can be linked to the container information provided by our electronical Response message (APERAK)

!This aperak will not be sent in the first fase.

SEGMENT TABLE

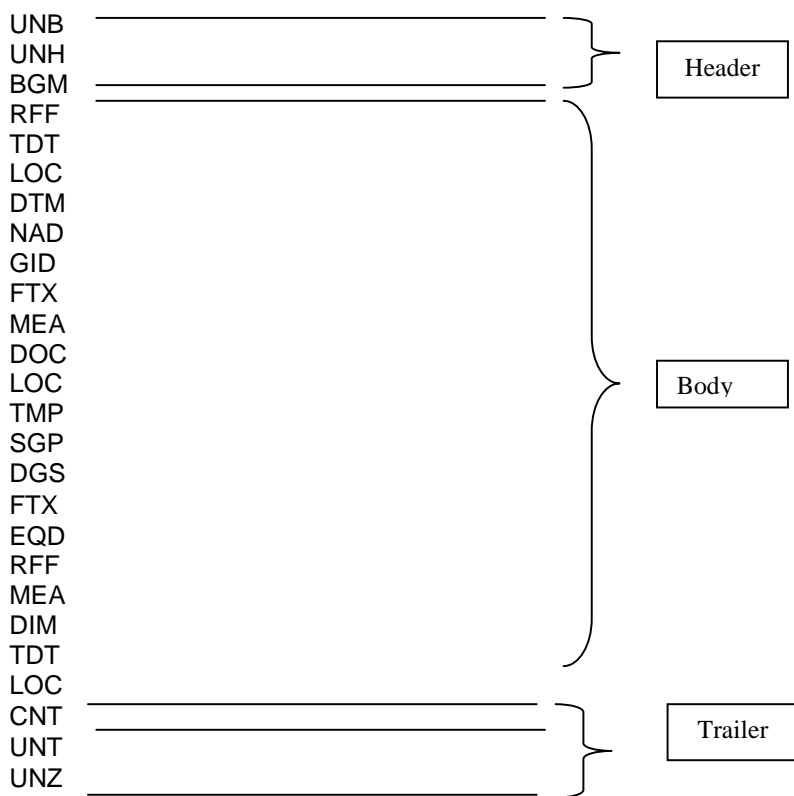

1. Interchange header – UNB - segment

Structure:

UNB

+

0001 = Syntax identifier with as value “UNOA”

:

0002 = Syntax version number with as value “2”

+

0004 = Sender identification: mailbox number of the message sender

+

0010 = Recipient identification: mailbox number of the message recipient

+

0017 = Date of preparation (YYMMDD)

:

0019 = Time of preparation (HHMM)

+

0020 = Interchange control reference with a unique number which is also specified in the UNZ segment

,

Example:

UNB+UNOA:2+<SENDER>+PSAHNN+000508:1106+000005

2. Message version – UNH-Segment

For mapping reasons, also enter the Association Assigned Code (0057) in the UNH-segment.

Structure:

UNH
+
0062 = *Message reference number* with as value a unique sequence number per message
+
0065 = *Message type identifier* with as value "COPINO"
:
0052 = *Message type version number* with as value "D"
:
0054 = *Message type release number* with as value "95B"
:
0051 = *Controlling agency* with as value "UN"
:
0057 = *Association assigned code* with as value the used manual version number (= "ITG13")
,

Example:

UNH+0002132+COPINO:D:95B:UN:ITG13'

3. Instruction type – BGM-Segment

For a discharge instruction, the value of data element 1001 is “660”

Structure:

BGM

+

1001 = *Instruction type* with as value “660” (=pre announcement discharge instruction)

+

1004 = *Document/message number*

+

1225 = *Message function, coded* with as value “9” (= original message) or “3” (=delete)

,

Example for discharge instruction:

BGM+**660**+20000002132+9'

Message function - BGM-Segment

In the BGM segment, the code value of data element 1225 (message function, coded) indicates the function of the message.

Only create (9) and delete (3) are allowed.

For adding new containers, a new create message (code 9) has to be sent.

To change information of a container, the container info needs to be deleted first and then a new creation can be sent.

9 = ORIGINAL (CREATE): First transmission of the message

To send the original instruction, the message function in BGM (1225) is “9”. The reference qualifier in the RFF segment (1153) has to be “XXX”, followed by the reference number (1154) with value “1” (= dummy value). For structure: see “Reference” below.

3 = DELETE

To delete an original instruction, the message function in BGM (1225) is “3”. The reference qualifier in the RFF segment (1153) has to be the reference number of the creation message.

For structure: see “Reference”

4. Reference – RFF-segment

This RFF segment is used to transmit references which apply to the whole message and which will link this message to later messages, reports/ instructions which relate to the equipment movement. The RFF segment is mandatory.

Structure:

RFF

+

1153 = Reference qualifier with as value "XXX" (= dummy value for original message) for ORIGINAL.
"ACW" (= Reference to a previous message) for deletion.

:

1154 = Reference number

,

Example:

Create:

```
UNB+UNOA:2+ABC+PSAHNN+000504:1040+34'  
UNH+0002132+COPINO:D:95B:UN:ITG10'  
BGM+660+223322+9'  
RFF+XXX:1'  
TDT+1+0035+8+++ABC+++1234567:146::COPINO TESTLICHTER'  
LOC+7+BEANR:139:6+BEANR869:TER:ZZZ'  
DTM+133:20004230:203'  
NAD+MS+ABC  
...
```

Delete:

```
UNB+UNOA:2+ABC+PSAHNN+000504:1040+34'  
UNH+0002132+COPINO:D:95B:UN:ITG10'  
BGM+660+223323+3'  
RFF+ACW:223322'  
TDT+1+0035+8+++ABC+++1234567:146::COPINO TESTLICHTER'  
LOC+7+BEANR:139:6+BEANR869:TER:ZZZ'  
DTM+133:20004230:203'  
NAD+MS+ABC  
...
```

5. Vessel details – Group1 – TDT Segment

This segment specifies the transport details such as mode of transport, reference numbers, ...
This segment is mandatory.

Structure:

TDT

+

8051 = *Transport stage qualifier* with as value "1" (=Inland transport)

+

8028 = *Conveyance reference number* with as value the BTS ID number

+

8067 = *Mode of transport, coded* with as value "8" (= Inland water)

++

3127 = *Carrier identification* with as value the code of the barge operator

:

1131 = *Code list qualifier* with as value "172" (= carrier code)

:

3055 = *Code list responsible agency, coded* with as value "20" (=BIC)

+++

8213 = *Id of means transport* with as value the Europe number.

:

1131 = *Code list qualifier* with as value "146"

::

8212 = *Id of the means of transport* with as value the full name of the barge

,

Example:

TDT+1+123456+8++ABC:172:20+++12345678:146::COPINO TESTLICHTER'

6. PLACE / LOCATION IDENTIFICATION – Group 1 – LOC-segment

Place of delivery

This segment is used to specify information about the port / terminal of delivery.
This segment is mandatory.

The Related Location One Identification (3223) can have one of the following values:

“BEANR869” or “0S869” for quay 869, Europa terminal
“BEANR420” or “00420” for quay 420, Churchlldok
“BEANR913” or “0S913” for quay 913, Noordzeeterminal
“BEANR1742” or “01742” for quay 1742, Deurganckdok

Structure:

LOC

+

3227 = *Place/location qualifier* with as value “7” (= place of delivery) → in case of discharge

+

3225 = *Place/location identification* with as value the UN-Locode of port of departure (“BEANR” for Antwerp or NLRTM for Rotterdam).

:

1131 = *Code list qualifier* with as value the code “139” (=port)

:

3055 = *Code list responsible agency, coded* with as value the code “6” (= UN)

+

3223 = *Related place/location one identification* with as value the terminal/berth of departure (for codes: see above)

:

1131 = *Code list qualifier* with as value the code “TER” (= terminal)

:

3055 = *Code list responsible agency, coded* with as value “ZZZ” (= mutually agreed)

,

Examples:

For discharge instruction:

LOC+7+BEANR:139:6+BEANR869:TER:ZZZ'

LOC+7+BEANR:139:6+0S869:TER:ZZZ'

(See <http://www.smdg.org> → documents → code lists → SMDG Terminal Facilities codes list.)

7. Date/time of arrival of the means of transport – Group 1 – DTM-Segment

This segment is to specify the date/time of arrival of the means of transport. This should be consistent with the time of arrival confirmed in the planning on BTS (Barge Traffic System).

This segment is optional.

Structure:

DTM

+

2005 = *Date/time/period qualifier* with as value 132 (= arrival date/time)

:

2380 = *Date/time/period* with as value the date and time of arrival given by BTS

:

2379 = *Date/time/period format qualifier* with as value 203 (CCYYMMDDHHMM)

,

Example:

DTM+132:200707161654:203'

8. Barge operator – Group 2 – NAD-segment

This segment specifies the name/address and their related function.

8A. Message Sender and message receiver ID

This segments are mandatory.

Structure:

NAD
+
3035 = *Party qualifier* with as value “MS” (= Message sender) and “MR”(= Message receiver).
+
3039 = *Party id identification* with as value the name of the barge operator
,

Example:

NAD+MS+ABC'
NAD+MR+PSAHNN'

8B. Container Operator

This segment is mandatory.

Structure:

NAD
+
3035 = *Party qualifier* with as value “CF” (= Container Operator)
+
3039 = *Party id identification* with as value the name of the line agency (See appendix C)
,

Example:

NAD+CF+ZZZ'

9. GOODS ITEM DETAIL – Group 3 – GID segment

This segment is used to describe goods items.

This segment is mandatory when goods item details are present for a container.

Structure:

GID

+

1496 = *Goods item number* coded with as value "1"

,

Example:

GID+1'

10. Free Text

Specifying goods information should be done in the FTX segment with as Text Subject Qualifier AAA (Goods description) or AAI (= general information).

Structure:

FTX

+

4451 = *Text Subject qualifier* with as value "AAA" or "AAI"

+++

4440 = *Free Text* with as value a description / instruction / remark.

'

Example:

FTX+AAA+++ZINC PLATE'

FTX+AAI+++HEAVY PAYLOAD'

11. Container Gross Weight – Group 3 – MEA segment

In this segment, the gross weight of the goods, excluding the tare weight of the container, is specified.

Structure:

MEA

+

6311 = *Measurement Application Qualifier* with as value "AAE" (=measurement)

+

6313 = *Measurement dimensions*, coded with as value "G" (= goods gross weight = weight of content of container, excluding carrier's equipment)

+

6411 = *Measure unit qualifier* with as value "KGM" (=kilogram)

:

6414 = *Measurement value* with as value the actual gross weight

'

Example:

MEA+AAE+G+KGM:24000'

12. Documents – Group 3 – DOC segment

This segment identifies documents, either printed, electronically transferred, or referenced as specified in message description, including, where relevant, the identification of the type of transaction that will result from this message.

When the DOC segment is used, the LOC+91 segment is mandatory for export containers (see p 16).

Structure:

DOC
+
1001 = *Document/message name*, coded 811, 821, ...
+
1004 = *Document number*
,

Codes Document/message name:

100 = *Excise Certificate* (Document **AGD**)
811 = *Export Licence* (Document Type **EX** = ECS)
821 = *Despatch Note Model T1* (Document Type **T** = NCTS)
822 = *Despatch Note Model T2* (Document **COA**)
823 = *Control Document T5* (Document **T5**)
825 = *Despatch Note Model T2L* (Document **T2L**)
RAR = Army documents

Example:

Document type EX:

DOC+811+09BE00000012345678'

Document type T:

DOC+821+09BE00000023456789'

! The structure of the MRN number is 18 characters.

13. Document office of destination– group 3 – LOC – segment

To specify the final office of destination of the documents of the container for customs purposes. This segment is mandatory, when DOC segment is used (see p 15).

Structure:

LOC

+

3227 = *Place/Location* qualifier with as value 91

+

3124 = *Name and address* (“BE101000” for Antwerp, “BE343000” for Zeebrugge”,...)

‘

Example:

LOC+91+BE101000’

When more offices of destinations are given, an additional GID group must be sent.
(see examples on page 33)

14. Fixed reefer temperature specification – Group 3 – TMP-segment

To specify a fixed reefer temperature.

This segment is mandatory for full operational import reefer containers.

This segment is forbidden for export discharge. (For export: the temperature settings will be processed by the booking reference.)

The Group 3 TMP-Segment is used and is composed as follows:

The temperature setting (6246) is a 3-digit integer number. ("." excluded)

Structure

TMP

+

6245 = *Temperature qualifier* with as value "2" (= transport temperature)

+

6246 = *Temperature setting* with as value the actual fixed temperature (see below)

:

6411 = *Measure unit qualifier* with as value the code "CEL" (=Celcius)

,

Examples:

TMP+2+10.0:CEL' → returns 010°C

TMP+2+05.0:CEL' → returns 005°C

TMP+2+-05.0:CEL' → returns -005°C

15. Split Goods Placement – group 3 – SGP-segment

The SGP segment links the goods item specified in this GID group to a container specified in the EQD segment.

Structure:

SGP
+
8260 = *Equipment number*
,

Example:

SGP+////1234567'

...

EQD+CN+////1234567+2210:102:5++2+5'

...

16. Dangerous goods – Group 3 – DGS-segment

To specify dangerous goods.

This segment is mandatory for full import containers, containing dangerous goods.

This segment is forbidden for export discharge. (The temperature settings will be processed by the booking reference for export containers).

Maximum 9 dangerous goods segments can be specified in the DGS-group with a DGS-segment, followed by a FTX-segment with as text subject qualifier (4451) "AAD"(= dangerous goods technical name).

The DGS-segment is composed as follows:

Structure:

DGS

+

8273 = *Dangerous goods regulations* = "IMD"

+

8351 = *Hazard code identification* = IMDG Class Number or Sub Class Number

+

7124 = *UNDG Number*

'

Example:

DGS+IMD+8+1824'

DGS+9+3082++III'

→ The segregation group can be given in the DGS segment, but our system is not able to process this information yet.

17. Dangerous goods technical name:

As “FTX+AAA” is a general description of the goods in a container, the “FTX+AAD” segment is the more specific technical name per commodity.

In case there are more than 9 commodities for one container (for one EQD segment), we suggest specifying the 9 most important/dangerous goods.

Structure:

FTX

+

4451 = *Text Subject qualifier with as value “AAD” = (dangerous goods technical name)*

+++

4040 = *Free text*

,

Example:

FTX+AAD+++ACETIC ACID SOLUTIONS'

18. Equipment details – Group 4 – EQD-segment

To specify container or equipment details.
This segment is mandatory.

Structures:

EQD

+

8053 = *Equipment qualifier* with as value “CN” (=container)

+

8260 = *Equipment identification number* with as value the container number

+

8155 = *Equipment size and type identification* with as value the ISO code for the corresponding container

:

1131 = *Code list qualifier* with as value “102” (=size and type)

:

3055 = *Code list responsible agency, coded* with as value “5” (= ISO)

++

8249 = *Equipment status, coded* with as value “1” (=continental/depot), “2” (= export) or “3” (= import)

+

8169 = *Full/empty indicator, coded* with as value “4” (= empty) or “5” (= full)

,

Example

(for Full): EQD+CN+TSTU1234567+4210:102:5++2+5'

(for Empty): EQD+CN+TSTU1234567+4210:102:5++1+4'

19. Booking reference number – Group 4 – RFF-segment

In this segment, the corresponding booking reference can be specified.

This segment is mandatory for **export** containers (= containers to be loaded on vessel) and **empty** containers (= containers empty in for depot).

Structure:

RFF

+

1153 = *Reference qualifier* with as value "CAO" (=Acceptance order reference number)

:

1154 = *Reference number* with as value the corresponding booking reference

,

Example:

RFF+CAO:ABCD000001'

! References for empty delivery, must be the same reference as given by the shipping line agent. When no reference is needed, no RFF+CAO has to be sent in the COPINO message.
Containernumber can never be a reference.

(Example: 3th move containers (full discharged from vessel, full out and empty in within 30days) do not need a reference)

20. Sequence number – Group 4 – RFF-segment

When a GID group is used and no container number is specified in the EQD segment, the RFF+SQ number links to the number specified in the SGP segment.
In this case, the RFF+SQ segment is mandatory. In all other cases, the RFF+SQ segment is optional and when given, is used as a sequence number.
(Only numbers can be used in this segment)

Structure:

RFF
+
1153 = *Reference qualifier* with as value "SQ" (=Sequence number)
:
1154 = *Reference number*
,

Example:

RFF+SQ:1'

21. Container Weight – Group 4 – MEA-segment

In this segment, the gross weight of the corresponding container is specified.
This segment is mandatory.

Structure:

MEA

+

6311 = *Measurement Application Qualifier* with as value "AAE" (=measurement)

+

6313 = *Measurement dimensions*, coded with as value "G" (= gross weight = weight of container + content of container)

+

6411 = *Measure unit qualifier* with as value "KGM" (=kilogram)

:

6414 = *Measurement value* with as value the actual gross weight

'

Example:

MEA+AAE+G+KGM:24000'

22. Dimensions – Group 4 – DIM-segment

The DIM segment is used to specify out-of-gauge dimensions.
This segment is optional.

Structure:

DIM
+
6145 = *Dimension qualifier* with as value “5” or “6” or “7” or “8” or “9” (see below)
+
6411 = *Measure unit qualifier* with as value “CMT” (= centimeters)
:
6168 = *Length dimension* with as value the over-length
:
6140 = *Width dimension* with as value the over-width
:
6008 = *Height dimension* with as value the over-height
,

Examples:

For over-length, front:	DIM+5+CMT:20'
For over-length, back:	DIM+6+CMT:30'
For over-width, right:	DIM+7+CMT::15'
For over-width, left:	DIM+8+CMT::15'
For over-height:	DIM+9+CMT:::50'

Also a combination is possible, for example a container with an over-length of 20 cm, an over-width (right and left) of 10 cm and an over-height of 30 cm:

...
DIM+5+CMT:20'
DIM+7+CMT::10'
DIM+8+CMT::10'
DIM+9+CMT:::30'
...

23. Main- carriage information – Group 5 – TDT-segment

This segment is mandatory

Structure:

TDT

+

8051 = *Transport stage qualifier* with as value “20” (=main carriage)

+

8028 = *Conveyance reference number* with as value the carrier’s main voyage number (=optional)

+

8067 = *Mode of transport, coded* with as value “1” (= maritime transport)

++

3127 = *Carrier identification* with as value the code of the vessel operator

:

1131 = *Code list qualifier* with as value “172” (= carrier code)

:

3055 = *Code list responsible agency, coded* with as value “20” (=BIC)

+++

8213 = *Id of means transport* with as value the international radio call sign

:

1131 = *Code list qualifier* with as value “103” (= radio call sign)

::

8212 = *Id of the means of transport* with as value the full name of the vessel (= optional)

,

Examples:

- Full import containers:
(in case the containers are discharged from vessel Testvessel in the place of receipt (e.g. RTM NL))

TDT+20+0904+1++ZZZ:172:20+++TESTV:103::TESTVESSEL'

- Full export / empty depot containers:

TDT+20++1'

24. Location – Group 5 – LOC-segment

The LOC segment is used to report locations, which relate to the movement of the container. The port of departure of the barge can be specified in the LOC+5 segment.

This segment is mandatory.

Structure:

LOC

+

3227 = *Place/location qualifier* with as value "5" (= place of departure)

+

3225 = *Place/location identification* with as value the UN-Locode of the place of departure.

:

1131 = *Code list qualifier* with as value the code "139" (=port)

:

3055 = *Code list responsible agency, coded* with as value the code "6" (= UN)

+

3223 = *Related place/location one identification* with as value BICS code

'

Examples:

- Full import containers:

```
TDT+20+0904+1++ZZZ:20+++TESTV:103::TESTVESSEL  
LOC+5+NLRM:139:6'
```

- Full export / empty depot containers:

```
TDT+20++1'  
LOC+5+BEMEH:139:6'
```

Or

```
TDT+20++1'  
LOC+5+NLRM:139:6+NLDDE'
```

25. Control total – CNT-segment

This segment is mandatory, even when a control total isn't required by the receiving application. In that case, dummy values can be used.

Structure:

CNT

+

6069 = *Control qualifier* with as value "16" (=total number of equipment)

:

6066 = *Control value* with as value the actual number of EQD –segments.

,

Example:

CNT+16:1' => In case there is 1 EQD -segment in the message

26. Message trailer – UNT-segment

This segment is mandatory. It specifies the total number of segments.

Structure:

UNT

+

0074 = *Number of segments in the message (UNH & UNT included)*

+

0062 = *Message reference number with as value the same as in 0062 in UNH (see above)*

,

Example:

UNT+29+2' => When there are 29 segments in the message (UNH & UNT included) and the message reference in UNH is "2".

Examples of COPINO discharge orders:

Example of a COPINO discharge order of 1 full container for export purposes:

UNB+UNOA:2+ABC+PSAHNN+090310:0943+WCT0903100943'
UNH+WCT1+COPINO:D:95B:UN:ITG13'
BGM+660+1286024E1+9'
RFF+XXX:1'
TDT+1+240309+8+++ABC+++1234567:146::LICHTER COPINO'
LOC+7+BEANR+BEANR1742:TER:ZZZ'
DTM+132:200903100800:203'
NAD+MS+ABC
NAD+MR+PSAHNN'
NAD+CF+ZZZ'
GID+1'
FTX+AAA+++BENZOYLCHLORIDE'
MEA+AAE+G+KGM:20000'
DOC+811+09BEE0000006566942++1'
LOC+91+BE101000'
SGP+TEST11111111'
FTX+AAD+++BENZOYLCHLORIDE'
EQD+CN+TEST11111111+2210:102:5++2+5'
RFF+CAO:ANT12345'
MEA+AAE+G+KGM:22500'
TDT+20++1'
LOC+5+BEMEH+00ECM'
CNT+16:1'
UNT+23+WCT1'
UNZ+1+WCT0903100943'

Example discharge of 1 empty container:

UNB+UNOA:2+ABC+PSAHNN+081001:1809+WCT0810011809'
UNH+WCT0+COPINO:D:95B:UN:ITG13'
BGM+660+1230809E1+9'
RFF+XXX:1'
TDT+1+291108+8++WTM+++1234567:146::LICHTER COPINO'
LOC+7+BEANR+BEANR1742:TER:ZZZ'
DTM+132:200811190730:203'
NAD+MS+ABC'
NAD+MR+PSAHNN'
NAD+CF+ZZZ'
GID+1'
EQD+CN+TEST222222+4310++1+4'
RFF+CAO:1234567'
MEA+AAE+G+KGM:4000'
TDT+20++1'
LOC+5+BEMEH+00ECM'
CNT+16:1'
UNT+17+WCT0'
UNZ+1+WCT0810011809'

Example of a COPINO discharge order of 1 full container for export purposes with different offices of destination:

UNB+UNOA:2+ABC+PSAHNN+081001:1809+WCT0810011809'
UNH+WCT13+COPINO:D:95B:UN:ITG13'
BGM+660+1208440E1+9'
RFF+XXX:1'
TDT+1+031008+8+++ABC+++1234567:146::LICHTER COPINO'
LOC+7+BEANR+BEANR1742:TER:ZZZ'
DTM+132:200810010600:203'
NAD+MS+ABC
NAD+MR+PSAHNN'
NAD+CF+ZZZ'
GID+1'
FTX+AAA+++KANE ACE PA610 SB'
MEA+AAE+G+KGM:19540'
DOC+811+09BEE0000006566942++1'
LOC+91+BE101000'
SGP+TEST3333333'
GID+2'
FTX+AAA+++KANE ACE PA610 SB'
MEA+AAE+G+KGM:19540'
DOC+811+08BE343000123456++1'
LOC+91+BE343000'
SGP+TEST3333333'
EQD+CN+TEST3333333+4510:102:5++2+5'
RFF+CAO:S170268400'
MEA+AAE+G+KGM:23540'
TDT+20++1'
LOC+5+BEMEH+00ECM'
CNT+16:1'
UNT+28+WCT13'
UNZ+1+WCT0810011809'

Example of a COPINO discharge order for 1 full import container:
(container discharged from vessel at an other terminal)

UNB+UNOA:2+ABC+PSAHNN+081001:1809+WCT0810011809'
UNH+WCT13+COPINO:D:95B:UN:ITG13'
BGM+660+1234567E1+9'
RFF+XXX:1'
TDT+1+031008+8+++ABC+++1234567:146::COPINO LICHTER'
LOC+7+BEANR+BEANR1742:TER:ZZZ'
DTM+132:200810010600:203'
NAD+MS+ABC
NAD+MR+PSAHNN'
NAD+CF+ZZZ'
GID+1'
FTX+AAA+++PARFUMERIEERZEUGNISSE'
MEA+AAE+G+KGM:19540'
TMP+2+18.0:CEL'
SGP+TEST1112223'
DGS+IMD+3+1266++III'
FTX+AAD+++PERFUMERY PRODUCTS'
EQD+CN+TEST1112223+22RE:102:5++3+5'
MEA+AAE+G+KGM:23540'
DIM+5+CMT:20'
TDT+20+0904+1+++MAE:172:20+++TESTV:103::TESTVESSEL'
LOC+5+NLRM:139:6'
CNT+16:1'
UNT+24+WCT13'
UNZ+1+WCT0810011809'

APPENDIX A : Some extra remarks on the use of free text segments :

Our main goal through the use of EDI is to process customer info automatically. Free text can not be interpreted by computers and therefore the use of free text should have to be kept to a strict minimum. A list of common misuse of the FTX segment is given below, also in addition, the consequences are mentioned.

☞ *Do not pass the goods description through use of the FTX+AAI segment. Use the FTX+AAA segment instead.*

This normally will go unnoticed by the Hesse-Noord Natie operational department (automated EDI processing).

☞ *Although this is a free text segment, some characters can't be used or can't be used without the preceding EDIFACT release character: "?" (according to level A character set). Here follows a list of most occurring "problem" –characters:*

➤ *“ “ “*

In EDIFACT, this character is known as a segment separator. If this character has to be interpreted as free text, it has to be preceded by the release character "?". Otherwise, the text after the "" character will be interpreted as a new segment with an error as result.

Example:

FTX+AAI+++1 x 20' FLAT' should be FTX+AAI:1 x 20?' FLAT'

➤ *“ + ”*

In EDIFACT, this character is known as a data element separator. If this character has to be interpreted as free text, it has to be preceded by "?". Otherwise, the text after the "+" character will be interpreted as a new data element with an error as result.

Example:

FTX+AAA+++TIRES + ENGINE PARTS' should be FTX+AAA:TIRES ?+ ENGINE PARTS'

➤ *“ : ”*

In EDIFACT, this character is known as a composite data element separator. If this character has to be interpreted as free text, it has to be preceded by "?". Otherwise, the text after the ":" character will be interpreted as a new composite data element with an error as result.

Example:

FTX+AAA+++FRUITS: APPLES AND PEACHES' should be FTX+AAA:FRUITS?: APPLES AND PEACHES'

➤ “ ? ”

In EDIFACT, this character is known as a release character and should never be used as free text. Sometimes this character is used as a question mark in free text at the end of an FTX segment. In that case, this “?” character should be preceded by another “?” character. Otherwise the system ignores a following data element –or segment separator with an error as result.

Example:

FTX+AAI+++DANGEROUS CARGO?’ should be FTX+AAI:DANGEROUS CARGO??’

➤ “ °”, “#”

In EDIFACT, these characters are not supported and should never be used.

🕒 **see also APPENDIX B for Level A character set details**

APPENDIX B: Level A character set in detail (see also “Interchange header – UNB –segment”):

Letters, upper case	A to Z
Numerals	0 to 9
Space character	
Full stop	.
Comma	,
Hyphen/minus sign	-
Opening parentheses (
Closing parentheses)	
Oblique stroke (slash) /	
Equals sign	=

Reserved for use as:

Apostrophe	' segment terminator
Plus sign	+ segment tag and data element separator
Colon	: component data element separator
Question mark	? release character

? immediately preceding one of the characters ' + : ? restores their normal meaning. E.g. 10?+10=20 means 10+10=20. Question mark is represented by ??.

The following characters are part of the level A character set but **cannot** be used internationally in telex transmissions:

Exclamation mark	!
Quotation mark	"
Percentage sign	%
Ampersand	&
Asterisk	*
Semi-colon	;
Less-than sign	<
Greater-than sign	>
Degree sign	°
Cross sign	#

Appendix C

Container Operator	Description
AAW	AUSTRALIAN NATIONAL LINE
ACL	ATLANTIC CONTAINER LINE
ACS	ATLANTIC CARGO
ALP	OPDR
ANZ	DSR ZUID AFRIKA
APL	AMERICAN PRESIDENT LINE
BAC	BACOLINER
BGF	BG FREIGHT LINE
CCL	COSCO CONTAINERLINE
CCN	TEAMW
CHI	CHINA SHIPPING CONTAINER LINES
CMA	CMA-CGM
CST	CSAV
DEL	DELMAS ATLANTIQUE
ECS	EAST COAST SOUTH AMERICA SERVICE
EUC	EUCON
EVG	EVERGREEN
GNC	GRIMALDI LINES
HAR	HATSU MARINE LIMITED (RTM CALLS)
HAT	HATSU MARINE
HJS	HANJIN SHIPPING
HMC	HOLLAND MAAS CONTAINER LINE
HMS	HOLLAND MAAS SHIPPING
HPL	HAPAG-LLOYD N.V
HSA	HAMBURG SUD
HYU	HYUNDAI MERCHANT MARINE
IBA	Ibesco Container
ILA	ISCONT LINES AGENCY
IRC	IRISL CONTAINERLINE
KCO	K LINE
KIS	K LINE (ISRAEL)
KNC	K LINE (NORTH CHINA JAPAN)
KNS	KENYA NATIONAL SHIPPING LINE
KSA	K LINE (KSA SERVICE)
KTA	K LINE (AMERICA SERVICE)
LBR	LIBRA
LTP	LLOYD TRIESTINO
MAA	MARUBA SHIPPING
MAC	MACS SHIPPING CORPORATION
MAE	MAERSK
MAL	OOCL
MCA	MC ANDREWS
MEY	MEYER'SOHN
MIS	MISC
MIT	MITSUMI (RTMcalls)
MOL	MITSUMI OSK LINES
MSC	MEDITERRANEAN SHIPPING COMPANY S.A.

MSK	MAERSK E/I
NOA	NORASIA
NYK	N.Y.K LINES
OCI	DELMAS INDIAN OCEAN
OMT	OVERSEAS MARITIME TRANSPORT
OPS	OPDR ZUID SPANJE + ANDALUSIE
OTA	OTAL ATLANTIQUE
PIL	PACIFIC INTERNATIONAL LINES
RIC	RICKMERS LINIEN
SAM	SAMSKIP
SCI	SHIPPING CORPORATION OF INDIA
SCL	SAFMARINE CONTAINER LINES
SOP	OPDR MAROKKO
SSA	DEUTSCHE AFRIKA LINIEN
STE	STEINACHER
TRS	TRS
TSC	TSCHUDI
UAS	UNITED ARAB SHIPPING NV
UDB	United depots Belgium
UFS	UNITED FEEDER SERVICE
UNI	UNIFEEDER
WAF	DELMAS WEST AFRICA
WAL	WEST AFRICA LINIEN
WHL	WAN HAI LINES
XPL	X-PRESS CONTAINER LINES
YGL	YEMEN GULF LINE
YML	YANG MING MARINE TRANSPORT CORP.
ZIM	ZIM LINES