



# GUIDELINES

## **COPINO Load** Container Pre Announcement Order For barges

(D95B version 1.3)

Department : PSA Antwerp EDI Support team

July 2010

## **PSA Antwerp Guidelines COPINO**

### **Introduction**

This document is composed merely to facilitate the development of new EDI COPINO links with our customers and to guide and assist them through the programming and test phase. This should reduce the research and development on the customer side significantly.

As PSA Antwerp is an active participant of the world wide SMDG EDI discussion forum since its foundation, this document is partially based on the SMDG COPINO user manual (Version 1.3), enriched with some useful tips. It is not our intention to replace the official SMDG manual. These guidelines should be used in addition to the COPINO manual.

Suggestions and/or feedback are always welcome, as this document is also based on experiences, gained from past EDI projects. Each time some new features are added, we provide our customers with an update.

Best regards,

The PSA Antwerp EDI support team

# COPINO loading order for barges

## The Container Pre Announcement Message for barges (COPINO)

The COPINO message is sent by the barge operator to the container terminal operator. It contains a list of all the full and empty containers to be loaded on barge.

The accuracy of the container information in this message is of innumerable importance. In order to send an up to date COPINO message, the load information can be linked to the container information provided by our electrical Response message (APERAK)  
!This aperak will not be sent in the first fase.

### SEGMENT TABLE

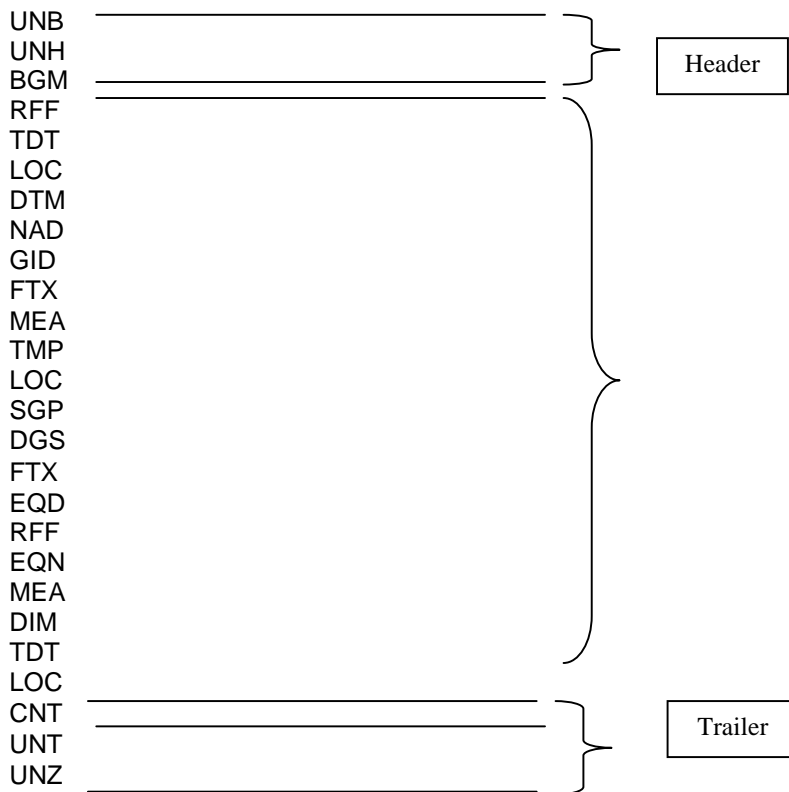

## 1 Interchange header – UNB –segment

### Structure:

UNB

+

0001 = Syntax identifier with as value “UNOA” (indicates the use of level ‘A’ character set. => see *APPENDIX B for more information*)

:

0002 = Syntax version number with as value “2”

+

0004 = Sender identification: mailbox number of the message sender

+

0010 = Recipient identification: mailbox number of the message recipient

+

0017 = Date of preparation (YYMMDD)

:

0019 = Time of preparation (HHMM)

+

0020 = Interchange control reference with a unique number which is also specified in the UNZ segment

,

### Example:

UNB+UNOA:2+<SENDER>+PSAHNN+000508:1106+000005

## 2 **Message version - UNH-Segment**

For mapping reasons, also enter the Association Assigned Code (0057) in the UNH-segment.

### Structure:

UNH

+

0062 = *Message reference number* with as value a unique sequence number per message

+

0065 = *Message type identifier* with as value "COPINO"

:

0052 = *Message type version number* with as value "D"

:

0054 = *Message type release number* with as value "95B"

:

0051 = *Controlling agency* with as value "UN"

:

0057 = *Association assigned code* with as value the used manual version number (= "ITG13")

,

### Example:

UNH+0002132+COPINO:D:95B:UN:ITG13'

### 3 Message function - BGM-Segment

In the BGM segment, the code value of data element 1225 (message function, coded) indicates the function of the message.

9 = ORIGINAL (CREATE): First transmission of the message

Only create (9) is allowed. For adding new containers, a new create message (code 9) has to be sent.

To send the original instruction, the message function in BGM (1225) is "9". The reference qualifier in the RFF segment (1153) has to be "XXX", followed by the reference number (1154) with value "1" (= dummy value). For structure: see "Reference" below.

#### Structure:

BGM

+

1001 = *Instruction type* with as value "661" (=pre announcement loading instruction)

+

1004 = *Document/message number*

+

1225 = *Message function, coded* with as value "9" (= original message)

,

#### Example for loading instruction:

BGM+661+20000002132+9'

#### 4 Reference – RFF segment

This RFF segment is used to transmit references which apply to the whole message and which will link this message to later messages, reports/ instructions which relate to the equipment movement. RFF segment is mandatory.

##### Structure:

RFF

+

1153 = Reference qualifier with as value "XXX" (= dummy value for original message) for ORIGINAL.

:

11454 = Reference number

,

##### Example:

UNB+UNOA:2+101600+PSAHNN+000504:1040+34'

UNH+0002132+COPINO:D:95B:UN:ITG10'

BGM+661+20000002132+9'

RFF+XXX:1'

TDT+1+310309+8++WTM+++1234567:146::COPINO TESTLICHTER'

LOC+88+BEANR:139:6+BEANR869:TER:ZZZ'

DTM+133:20004230:203'

NAD+MS+WTM'

...

## 5 Vessel details - Group1 TDT Segment

This segment specifies the transport details such as mode of transport, reference numbers, ...  
This segment is mandatory.

### Structure:

TDT

+

8051 = *Transport stage qualifier* with as value "1" (=Inland transport)

+

8028 = *Conveyance reference number* with as value the BTS ID number

+

8067 = *Mode of transport, coded* with as value "8" (= Inland water)

++

3127 = *Carrier identification* with as value the code of the barge operator

:

1131 = *Code list qualifier* with as value "172" (= carrier code)

:

3055 = *Code list responsible agency, coded* with as value "20" (=BIC)

+++

8213 = *Id of means transport* with as value the Europe number.

:

1131 = *Code list qualifier* with as value "146"

::

8212 = *Id of the means of transport* with as value the full name of the barge (= optional)

,

### Example:

TDT+1+310309+8++WTM:172:20+++1234567:146::COPINO TESTLICHTER'

## 6 Place of receipt - Group 1 LOC-segment

This segment is used to specify information about the port / terminal of loading.

The Related Location One Identification (3223) can have one of the following values:

“BEANR869” or “0S869” for quay 869, Europa Terminal  
“BEANR420” or “00420” for quay 420, Churchilldok  
“BEANR913” or “0S913” for quay 913, Noordzeeterminal  
“BEANR1742” or “01742” for quay 1742, Deurganckdok

### Structure:

LOC

+

3227 = *Place/location qualifier* with as value “88” (= place of receipt)

+

3225 = *Place/location identification* with as value the UN-Locode of port of departure (“BEANR” for Antwerp or “BEZEE” for Zeebrugge)

:

1131 = *Code list qualifier* with as value the code “139” (=port)

:

3055 = *Code list responsible agency, coded* with as value the code “6” (= UN)

+

3223 = *Related place/location one identification* with as value the terminal/berth of departure (for codes: see above)

:

1131 = *Code list qualifier* with as value the code “TER” (= terminal)

:

3055 = *Code list responsible agency, coded* with as value “ZZZ” (= mutually agreed)

,

### Example:

LOC+88+BEANR:139:6+BEANR869:TER:ZZZ'

LOC+88+BEANR:139:6+0S869:TER:ZZZ'

(See <http://www.smdg.org/> → documents → code lists → SMDG Terminal Facilities codes list.)

## **7 Date/time of arrival of the means of transport – Group 1 DTM Segment**

This segment is to specify the date/time of arrival of the means of transport. This should be consistent with the time of arrival confirmed in the planning on BTS ( Barge Traffic System).

### Structure:

DTM

+

2005 = *Date/time/period qualifier* with as value 132 (= arrival date/time)

:

2380 = *Date/time/period* with as value the date and time of arrival given by BTS

:

2379 = *Date/time/period format qualifier* with as value 203 (CCYYMMDDHHMM)

'

### Example:

DTM+132:200707161654:203'

## **8 Shipping line service - Group 2 NAD-Segment**

This segment specifies the name/address and their related function.

### **8A. Message Sender and message receiver ID**

#### Structure:

NAD

+

3035 = *Party qualifier* with as value "MS" (= Message sender) and "MR"(= Message receiver).

+

3039 = *Party id identification* with as value the name of the barge operator

#### Example:

NAD+MS+WCT'

NAD+MR+PSAHNN'

## 9 GOODS ITEM DETAIL – Group 3 – GID segment

This segment is used to describe goods items.

This segment is mandatory when goods item details are present for a container.

### Structure:

GID

+

1496 = *Goods item number* coded with as value "1"

,

### Example:

GID+1'

## 10 Free Text

Specifying goods information should be done in the FTX segment with as Text Subject Qualifier AAA (Goods description) or AAI (= general information).

This segment is optional.

### Structure:

FTX

+

4451 = *Text Subject qualifier* with as value "AAA" or "AAI"

+++

4440 = *Free Text* with as value a description / instruction / remark.

'

### Example:

FTX+AAA+++ZINC PLATE'

FTX+AAI+++HEAVY PAYLOAD'

## **11 Container Gross Weight – Group 3 – MEA segment**

In this segment, the gross weight of the goods, excluding the tare weight of the container, is specified.

### Structure:

MEA

+

6311 = *Measurement Application Qualifier* with as value "AAE" (=measurement)

+

6313 = *Measurement dimensions*, coded with as value "G" (= goods gross weight = weight of content of container, excluding carrier's equipment)

+

6411 = *Measure unit qualifier* with as value "KGM" (=kilogram)

:

6414 = *Measurement value* with as value the actual gross weight

'

### Example:

MEA+AAE+G+KGM:20000'

## **12 Fixed reefer temperature specification – Group 3 – TMP segment**

To specify a fixed reefer temperature. This segment is optional for COPINO load instructions.

## **13 Split Goods Placement – group 3 – SGP-segment**

The SGP segment links the goods item specified in this GID group to a container specified in the EQD segment.

### Structure:

SGP  
+  
8260 = *Equipment number*  
,

### Example:

- When container number is known:

```
...  
SGP+TEST1234567'  
...  
EQD+CN+TEST1234567+2210:102:5++2+5'  
...
```

- For empty containers:

```
...  
SGP+001:AGP:ZZZ'  
...  
EQD+CN++2210:102:5++3+4'  
...
```

#### **14 Dangerous goods – Group 3 – DGS-Segment**

To specify dangerous goods. This segment is optional for COPINO load instructions.

#### **15 Equipment details - Group 3 EQD-Segment**

##### Structures:

EQD

+

8053 = *Equipment qualifier* with as value "CN" (=container)

+

8260 = *Equipment identification number* with as value the container number

+

8155 = *Equipment size and type identification* with as value the ISO code for the corresponding container or length, type, height

:

1131 = *Code list qualifier* with as value "102" (=size and type)

:

3055 = *Code list responsible agency, coded* with as value "5" (= ISO) or "SE" (when isocode is not known)

++

8249 = *Equipment status, coded* with as value "2" (= export) or 3 (= import)

+

8169 = *Full/empty indicator, coded* with as value "4" (= empty) or "5" (= full)

,

##### Example

EQD+CN+TEST1234567+4210:102:5++2+5'

EQD+CN+TEST1234567+4210:102:5++2+4'

EQD+CN++4210:102:5++2+4'

EQD+CN+TEST1234567+20DV86:102:SE++2+5'

EQD+CN++40CT86:102:SE++2+4'

(See <http://eportal.psahnn.be/eportalv2/Default.aspx> → codes → ISO codes)

## **16 Booking reference number - Group 4 RFF-Segment**

In this segment, the corresponding release order reference can be specified.

This segment is mandatory in case of load instructions for empty containers, when no containernumber is known. (RFF+REO)

If full containers are released with a pincode, the pincode can be given in this segment (RFF+ACD)

### Structure (for empty containers):

RFF

+

1153 = *Reference qualifier* with as value "REO" (= Release order reference number),

:

1154 = *Reference number* with as value the corresponding booking reference

,

### Example:

RFF+REO:ANTA000001'

Or

### Structure (for full containers):

RFF

+

1153 = *Reference qualifier* with as value "ACD" (=Additional reference number),

:

1154 = *Reference number* with as value the pincode

,

### Example:

RFF+ACD:121314'

### **!Note:**

! At this moment the pincode will be overruled by our system.

## 17 Sequence number – Group 4 – RFF-segment

The RFF+SQ segment is optional and when given, is used as a sequence number.

### Structure:

RFF  
+  
1153 = *Reference qualifier* with as value "SQ" (=Sequence number)  
:  
1154 = *Reference number*  
,

### Example:

RFF+SQ:001'

### **NOTE !!!**

To specify the number of empty units.

This segment has a value different from 1 (if it isn't one container) when the container number is not known for the booking references.

The maximum number of units (detail lines) in the EQN-segment (data element 6350) is limited to 999 detail lines per reference.

This segment is only to be used to load multiple empty containers for the same reference (please omit RFF+SQ segment then).

### Structure:

EQN  
+  
6353 = *Number of units*  
,

### Example:

EQN+5' → for an EQD-detail with 5 containers

## **18 Container Gross Weight - Group 3 MEA-Segment**

This segment is mandatory, and specifies the gross weight of the corresponding container (including the tare weight of the container).

### Structure:

MEA

+

6311 = *Measurement Application Qualifier* with as value "AAE" (=measurement)

+

6313 = *Measurement dimensions*, coded with as value "G" (= gross weight = tare weight of container + content of container)

+

6411 = *Measure unit qualifier* with as value "KGM" (=kilogram)

:

6414 = *Measurement value* with as value the actual gross weight

'

### Example:

MEA+AAE+G+KGM:24000'

## 19 Overheight / Oversized containers - Group 3 DIM-Segment

The Group 3 DIM-Segment is used to specify dimensions, which exceed those of the standard dimension reported in the preceding EQD-Segment. (The ISO code in the EQD segment specifies the standard size and the height of a container.)

This segment is optional.

## 20 General information - Group 3 FTX-Segment

Specifying general information should be done in the FTX segment with as Text Subject Qualifier (4451) "AAI" (=general information).

*!! Please note that a free text segment can't be interpreted by a computer system. Therefore we advise to put as less information as possible in this segment.*

### Structure:

FTX

+

4451 = *Text subject qualifier* with as value "AAI" (=general information)

+++

4440 = *Free text* with as value a description/instruction/remark (***Mind the fact that this data element only may be used once per FTX-segment!!***)

,

### Example:

FTX+AAI+++HEAVY PAYLOAD'

⇒ In case you want to specify more than one general remark, you have to enter separate FTX-segments. You can't specify different remarks in 1 FTX-segment because data element 4440 may only be used once per segment.

However, always mind the fact that there only may occur 9 FTX-segments per group 3 in total (included: FTX+AAA and FTX+HAN)

FTX+AAI+++HEAVY PAYLOAD'

FTX+AAI+++SENSITIVE TO MAGNETIC INTERFERENCE'

...

## 21 Main- carriage information – Group 4 TDT-Segment

Details concerning the transport mode of the main carriage (= the transport of the container when the container is to be loaded on a vessel at an other terminal different from the terminal where the containers are being loaded on barge), can be specified in this segment.

This segment will only be used in case of export.

This segment is mandatory for export loading

The data of the order reference sent by the agent will always take priority over the data sent in the COPINO message sent by the barge operator.

### Structure:

TDT

+

8051 = *Transport stage qualifier* with as value "20" (=main carriage)

+

8028 = *Conveyance reference number* with as value the carrier's main voyage number

+

8067 = *Mode of transport, coded* with as value "1" (= maritime transport)

++

3127 = *Carrier identification* with as value the code of the vessel operator

:

1131 = *Code list qualifier* with as value "172" (= carrier code)

:

3055 = *Code list responsible agency, coded* with as value "20" (=BIC)

+++

8213 = *Id of means transport* with as value the international radio call sign

:

1131 = *Code list qualifier* with as value "103" (= radio call sign)

::

8212 = *Id of the means of transport* with as value the full name of the vessel (= optional)

,

### Example:

- Full export containers:  
(in case the containers loaded on the barge will be loaded on vessel at a different terminal (eg. MSC INSA with call sign 3FW05)):

TDT+20++1++MSC:172:20+++3FWO5:103::MSC INSA'

- Full import / empty containers:

TDT+20'

## **22 Port of discharge - group 4 LOC- segment**

This segment is used to specify the terminal of discharge on barges point of view.  
On that terminal, the goods may be transhipped to another vessel and continue their voyage to their final port of destination or can be picked up by train, truck,...

This segment is mandatory.

### **Structure:**

LOC

+

3227 = *Place/location qualifier* with as value "7" (port of destination)

+

3225 = *Place/location identification* with as value the UN-Locode of (inland) place of loading in case of pre-carriage by truck or train,... or the port of loading in case of transhipment.

:

1131 = *Code list qualifier* with as value the code "139" (=port)

:

3055 = *Code list responsible agency, coded* with as value the code "6" (= UN)

+

3225 = *Place/location identification* with as value the BIC code.

:

1131 = *Code list qualifier* with as value the code "139" (=port)

:

3055 = *Code list responsible agency, coded* with as value the code "6" (= UN)

,

### **Examples:**

LOC+7+DEDUI:139:6+RRT:139:6'

### **23 Control total – CNT –segment**

This segment is always required, also when a control total isn't required by the receiving application. In that case, dummy values can be used.

#### **Structure:**

CNT

+

6069 = *Control qualifier* with as value "16" (=total number of equipment)

:

6066 = *Control value* with as value the actual number of EQD –segments.

,

#### **Example:**

CNT+16:13' → In case there are 13 EQD –segments in the message

## 24 Message trailer – UNT -segment

This segment is also mandatory. It specifies the total number of segments.

### Structure:

UNT

+

0074 = *Number of segments in the message* (UNH & UNT included)

+

0062 = *Message reference number* with as value the same as in 0062 in UNH (see above)

,

### Example:

UNT+29+2' → In case there are 29 segments in the message (UNH & UNT included) and the message reference in UNH is also "2"

### **Example of a COPINO load order for 1 full import container**

UNB+UNOA:2+WCT+PSAHNN+081001:1809+WCT0810011809'  
UNH+WCT13+COPINO:D:95B:UN:ITG13'  
BGM+661+1208440E1+9'  
RFF+XXX:1'  
TDT+1+2402+8++WTM:172:20+++1234567:146::COPINO TESTLICHTER'  
LOC+88+BEANR:139:6+BEANR1742:TER:ZZZ'  
DTM+132:200810010600:203'  
NAD+MS+WTM'  
NAD+MR+PSAHNN'  
GID+1'  
FTX+AAA+++KANE ACE PA610 SB'  
MEA+AAE+G+KGM:19540'  
SGP+TEST1111111'  
EQD+CN+TEST1111111+2210:102:5++3+5'  
MEA+AAE+G+KGM:23540'  
TDT+20++1'  
LOC+7+BEMEH:139:6+00ECM:139:6'  
CNT+16:1'  
UNT+18+WCT13'  
UNZ+1+WCT0810011809'

### **Example of a COPINO load order for 1 full export container**

UNB+UNOA:2+WCT+PSAHNN+081001:1809+WCT0810011809'  
UNH+WCT13+COPINO:D:95B:UN:ITG13'  
BGM+661+1208440E1+9'  
RFF+XXX:1'  
TDT+1+8536+8++WTM+++1234567:146::COPINO TESTLICHTER'  
LOC+88+BEANR:139:6+BEANR913:TER:ZZZ'  
DTM+132:200810010600:203'  
NAD+MS+WTM'  
NAD+MR+PSAHNN'  
GID+1'  
FTX+AAA+++KANE ACE PA610 SB'  
MEA+AAE+G+KGM:19540'  
SGP+TEST2222222'  
EQD+CN+TEST2222222+2210++2+5'  
MEA+AAE+G+KGM:23540'  
TDT+20++1++MSC:172:20+++11111:103::TESTW'  
LOC+7+NLRTM:139:6+00ECM:139:6'  
CNT+16:1'  
UNT+18+WCT13'  
UNZ+1+WCT0810011809'

**Example of a COPINO load order for 1 empty container**

UNB+UNOA:2+WCT+PSAHNN+081001:1809+WCT0810011809'  
UNH+WCT13+COPINO:D:95B:UN:ITG13'  
BGM+661+1208440E1+9'  
RFF+XXX:1'  
TDT+1+311009+8++WTM+++1234567:146::COPINO TESTLICHTER'  
LOC+88+BEANR:139:6+BEANR913:TER:ZZZ'  
DTM+132:200810010600:203'  
NAD+MS+WTM'  
NAD+MR+PSAHNN'  
GID+1'  
SGP+001:AGP:ZZZ'  
EQD+CN++2210++3+4'  
RFF+REO:12345'  
RFF+SQ:001'  
MEA+AAE+G+KGM:4000'  
TDT+20'  
LOC+7+BEMEH:139:6+00ECM:139:6'  
CNT+16:1'  
UNT+18+WCT13'  
UNZ+1+WCT0810011809'

**Example of a COPINO load order for 5 empty containers**

UNB+UNOA:2+WCT+PSAHNN+081001:1809+WCT0810011809'  
UNH+WCT13+COPINO:D:95B:UN:ITG13'  
BGM+661+1208440E1+9'  
RFF+XXX:1'  
TDT+1+311009+8++WTM+++1234567:146::COPINO TESTLICHTER'  
LOC+88+BEANR:139:6+BEANR913:TER:ZZZ'  
DTM+132:200810010600:203'  
NAD+MS+WTM'  
NAD+MR+PSAHNN'  
GID+1'  
EQD+CN++2210++3+4'  
RFF+REO:12345'  
**EQN+5'**  
MEA+AAE+G+KGM:4000'  
TDT+20'  
LOC+7+BEMEH:139:6+00ECM:139:6'  
CNT+16:1'  
UNT+17+WCT13'  
UNZ+1+WCT0810011809'

## **APPENDIX A : Some extra remarks on the use of free text segments :**

Our main goal through the use of EDI is to process customer info automatically. Free text can not be interpreted by computers and therefore the use of free text should have to be kept to a strict minimum. A list of common misuse of the FTX segment is given below, also in addition, the consequences are mentioned.

- ☞ Do not pass the goods description through use of the FTX+AAI segment. Use the FTX+AAA segment instead.

This normally will go unnoticed by the Hesse-Noord Natie operational department (automated EDI processing).

- ☞ Although this is a free text segment, some characters can't be used or can't be used without the preceding EDIFACT release character: "?" (according to level A character set). Here follows a list of most occurring "problem" –characters:

- " “ "

In EDIFACT, this character is known as a segment separator. If this character has to be interpreted as free text, it has to be preceded by the release character "?". Otherwise, the text after the "" character will be interpreted as a new segment with an error as result.

Example:

FTX+AAI+++1 x 20' FLAT' should be FTX+AAI:1 x 20?' FLAT'

- " + "

In EDIFACT, this character is known as a data element separator. If this character has to be interpreted as free text, it has to be preceded by "?". Otherwise, the text after the "+" character will be interpreted as a new data element with an error as result.

Example:

FTX+AAA+++TIRES + ENGINE PARTS' should be FTX+AAA:TIRES ?+ ENGINE PARTS'

- " : "

In EDIFACT, this character is known as a composite data element separator. If this character has to be interpreted as free text, it has to be preceded by "?". Otherwise, the text after the ":" character will be interpreted as a new composite data element with an error as result.

Example:

FTX+AAA+++FRUITS: APPLES AND PEACHES' should be FTX+AAA:FRUITS?: APPLES AND PEACHES'

➤ “ ? ”

*In EDIFACT, this character is known as a release character and should never be used as free text. Sometimes this character is used as a question mark in free text at the end of an FTX segment. In that case, this “?” character should be preceded by another “?” character. Otherwise the system ignores a following data element –or segment separator with an error as result.*

*Example:*

*FTX+AAI+++DANGEROUS CARGO?’ should be FTX+AAI:DANGEROUS CARGO??’*

➤ “ °”, “#”

*In EDIFACT, these characters are not supported and should never be used.*

🔍 **see also APPENDIX B for Level A character set details**

**APPENDIX B: Level A character set in detail (see also “Interchange header – UNB –segment”):**

Letters, upper case	A to Z
Numerals	0 to 9
Space character	
Full stop	.
Comma	,
Hyphen/minus sign	-
Opening parentheses	(
Closing parentheses	)
Oblique stroke (slash)	/
Equals sign	=

Reserved for use as:

Apostrophe	' segment terminator
Plus sign	+ segment tag and data element separator
Colon	: component data element separator
Question mark	? release character

? immediately preceding one of the characters ' + : ? restores their normal meaning. E.g. 10?+10=20 means 10+10=20. Question mark is represented by ??.

The following characters are part of the level A character set but **cannot** be used internationally in telex transmissions:

Exclamation mark	!
Quotation mark	"
Percentage sign	%
Ampersand	&
Asterisk	*
Semi-colon	;
Less-than sign	<
Greater-than sign	>
Degree sign	°
Cross sign	#